

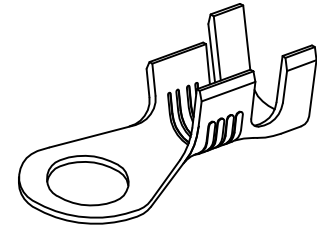

PARÇA KODU PART CODE	PARÇA ADI PART NAME	s ÖLÇÜSÜ (KALINLIK) s MEASURE (THICKNESS)	Malzeme Material	Kaplama / Coating		
				SN	AG	Nİ
TŞ 2418 DP	2.5 NO KABLO UÇ B.A.Ø5.2 =DP=	0.45±0.05	(CuZn30) Pirinç / Brass	-	-	-
TŞ 2418 RP	2.5 NO KABLO UÇ B.A.Ø5.2 =RP=	0.45±0.05	(CuZn30) Pirinç / Brass	-	-	-
TŞ 2418 RPK	2.5 NO KABLO UÇ B.A.Ø5.2 =RPK=	0.45±0.05	(CuZn30) Pirinç / Brass	+	-	-
TŞ 2418 RÇN	2.5 NO KABLO UÇ B.A.Ø5.2 =RÇN=	0.50±0.05	Paslanmaz Sac(430)	-	-	+
TŞ 2418.50 RP	2.5 NO KABLO UÇ B.A.Ø5.2 =RP=	0.50±0.05	(CuZn30) Pirinç / Brass	-	-	-
TŞ 2418.50 RPK	2.5 NO KABLO UÇ B.A.Ø5.2 =RPK=	0.50±0.05	(CuZn30) Pirinç / Brass	+	-	-

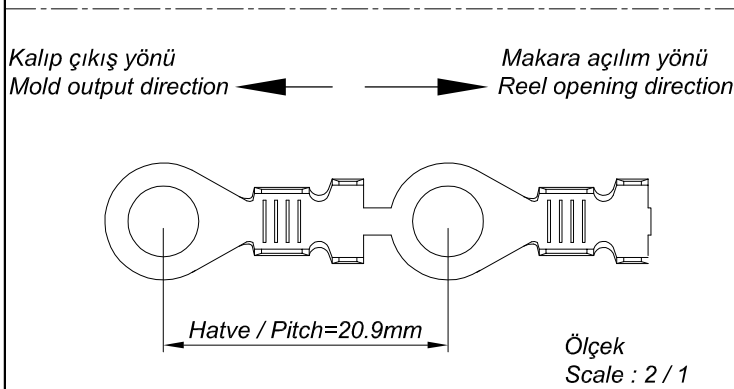
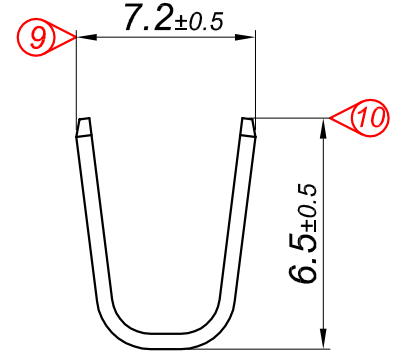
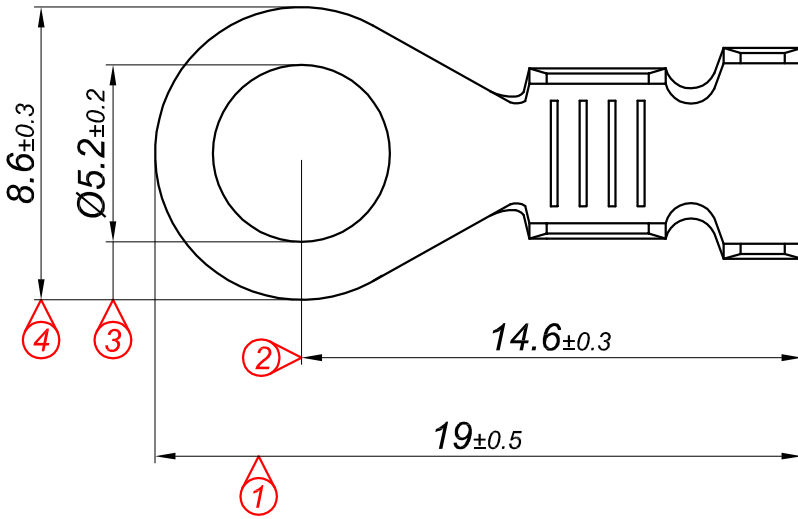
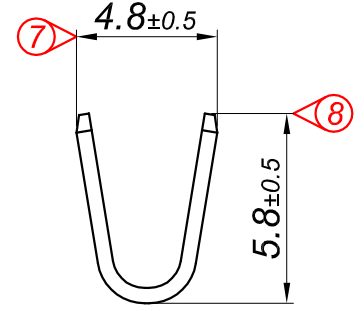
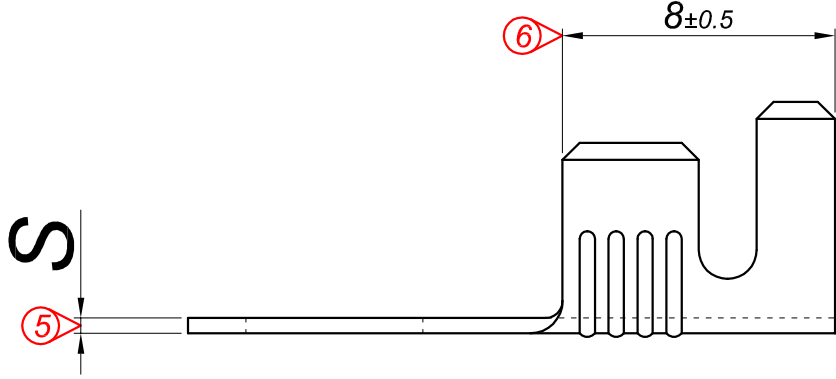

Perspektif
Perspective

Kablo Kesiti
Wire Section : 2.50 - 6 mm²

Resim üzerinden ölçü almayınız
do not measure on drawing

Tarih / Date	19.07.2013	İmza / Signature	Ölçek / Scale			
Çizen / Desing	M.Yağcı		5 / 1	01	Çiftli kalıp yapılmıştır, Ölçüler yeniden düzenlenmiştir.	03.04.2015
Onay / Approval	S.Gölcük			No	Değişiklik / Revision	Tarih/Date
	Parça Adı: Part Name	2.5 NO KABLO UCU BÜYÜK AYAK Ø5.2		Parça Kodu: Part Code	TŞ 2418	